

Montpellier

THE PERFECT BALANCE OF FUNCTION AND STYLE

LAUNDRY - DISHWASHING - COOKING - COOLING

Installation and Operating Instructions



Portable Air Conditioner

MAC9000W

MAC12000W

Please read these instructions carefully before attempting to install or use this appliance.
We recommend that you keep these instructions in a safe place for future reference.

Welcome

Thank you for choosing this Montpellier appliance.

Our appliances have been designed to provide you with the best combination of style, reliability and performance to give you years of trouble-free use.

You may be familiar with a similar product, but please take time to read these instructions carefully before installing or using your appliance to ensure you get the most from your purchase.



2
YEAR
GUARANTEE
— PARTS & LABOUR —
ACROSS ALL OUR MODELS
Montpellier
www.montpellier-appliances.com

We recommend that you keep this manual in a safe place for future reference.

Your appliance is covered by a comprehensive two year Parts & Labour Guarantee. In the unlikely event that you experience a problem with your appliance, you can rest assured that you are fully protected against the cost of repairs for the first 24 months. Please note that any claim must be accompanied by the model reference number, serial number and proof of purchase.

To activate your guarantee, you will need your product serial number. This can be found inside your appliance.

NB: Please make sure that you keep a copy of your original sales invoice as this will be needed if any service call is required.

There are three ways to register your Guarantee:

- **Online:** Visit the Support page on our website and complete the online Product Registration form. www.montpellier-appliances.com
- **By Post:** Simply detach and fill in the form provided, attach a stamp and send it in the post. Don't forget to include your e-mail address so that we can send confirmation through to you.
- **By Phone:** Contact our warranty registration department on **0808 1961388**

Thank you for choosing this product.

This User Manual contains important safety information and instructions on the operation and maintenance of your appliance.

Please take the time to read this User Manual before using your appliance and keep this book for future reference.

The design and specifications are subject to change without prior notice for product improvement.

CONTENT

Important Safety Tips

Precautions 1

Product Introduction

Main Parts and Components..... 3

Control Panel and Remote Controller..... 4

Product Operation

Placement and Installation..... 5

Operation Method 7

Clean and Maintenance

Drainage Method..... 8

Maintenance..... 8

Common Failures and Diagnosis

Intelligent Error Detection 10

Fuse Parameters..... 10

Trouble-shooting..... 10

IMPORTANT SAFETY TIPS

PRECAUTION

Please read the Manual carefully before operating the machine:

- This machine is for household use only.
- This machine is for indoor use only. Please place it in dry environment.
- Check power cord frequently. When power cord, plug or A/C is damaged, please don't operate.

If the power cord is not long enough, power extension cable can be used. Cable should not scatter at places where power cord may be pulled out or people may be stumbled.

- The A/C should be away from heat source and avoid direct sunlight.
- Turn off the A/C before unplugging.
- Turn off and unplug the A/C before removing or cleaning it, or replacing its parts or when it is not used.
- Clean the A/C according to the Manual.
- Voltage of the A/C should meet requirements. Any damage incurred by incorrect power isn't included in the warranty.
- Children are not allowed to play with the A/C.

This appliance is not intended for use by persons (including children) with reduced physical, sensory or mental capabilities, or lack of experience and knowledge, unless they have been given supervision or instruction concerning use of the appliance by a person responsible for their safety.

- Don't insert your fingers or any hard object to wind guide bar of the air outlet.
- Don't place the A/C at any place with water or other liquid. Prevent water or liquid from entering the A/C.
- Don't repair the A/C by yourself. Any possible hazard incurred by maintenance of laypeople will violate the warranty. If the supply cord is damaged, it must be replaced by professional maintenance personnel.
- Please use the accessories provided by the A/C manufacturer; otherwise, the A/C may be damaged.
- Suggest using environmental temperature for the air conditioner (Cooling/heating) : 15—35°C/5-27°C.
- This appliance can be used by children aged from 8 years and above and persons with reduced physical, sensory or mental capabilities or lack of experience and knowledge if they have been given supervision or instruction concerning use of the appliance in a safe way and understand the hazards involved. Children shall not play with the appliance. Cleaning and user maintenance shall not be made by children without supervision.

Special warning:

- Place the A/C on even ground and install it vertically, so as to ensure normal operation of the compressor.
- The A/C should be at least 50cm away from surrounding objects. Keep air inlet and outlet smooth.
- Don't use the A/C beside gasoline or any other inflammable liquid.
- Don't use spraying agent and other solvent or flammable substances near the A/C; otherwise, its plastic may deform and electric parts may be damaged.

Power

- The plug should be in good condition and can't be damaged. Don't replace the plug with power lug.
- In order to run the A/C, plug the power cord first, and then press the power key.

PRODUCT INTRODUCTION

MAIN PARTS AND COMPONENTS

1. Handle
2. Air inlet (L)
3. Control panel
4. Wind guide bar
5. Caster
6. Remote controller
7. Air inlet (R)
8. Air outlet
9. Dehumidification drainage nozzle
10. Air inlet grille
11. Exhaust duct assembly
12. Window sealing plate assembly

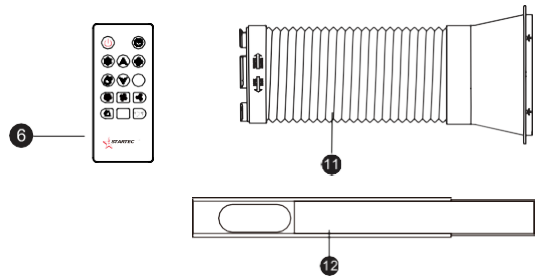
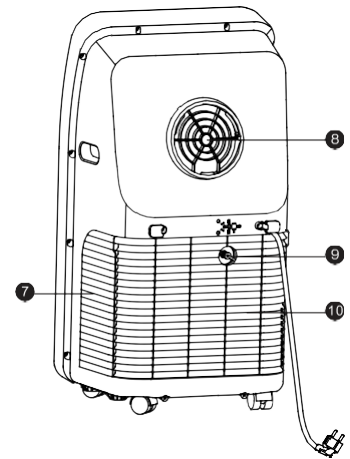
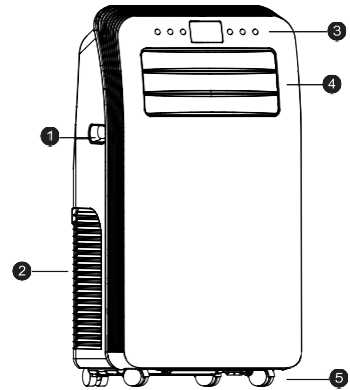

CONTROL PANEL AND REMOTE CONTROLLER

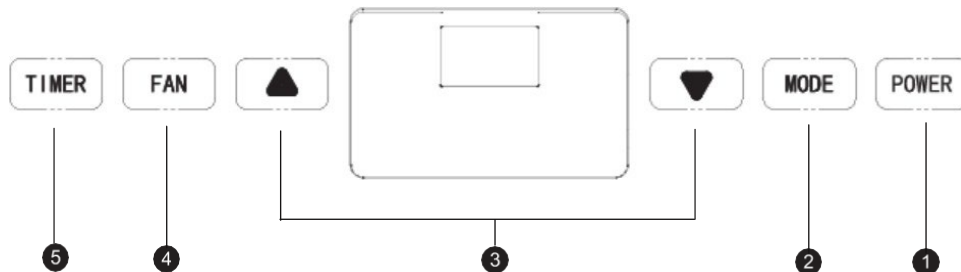

1. Power key

Press the key to turn ON/OFF the A/C.

2. Mode key

Press the key to choose cooling, wind, dehumidification and heating (cooling only model has no heating) mode.

3. Temperature/ time adjusting key

Press the key at cooling mode to increase/reduce the setting temperature; press it at timing mode to adjust timing ON/OFF time; press Up and Down keys simultaneously to switch Fahrenheit and Centigrade degree temperature.

4. Fan key

Press the key to choose high/ low gear wind speed.

5. Timer Key

press this key to set a timer for auto start or auto stop.

6. Swing key

Press this key at any time after turning on the A/C to swing the wind guide bar automatically.

7. °C/ °F switching key

Press the key to switch °C and °F.

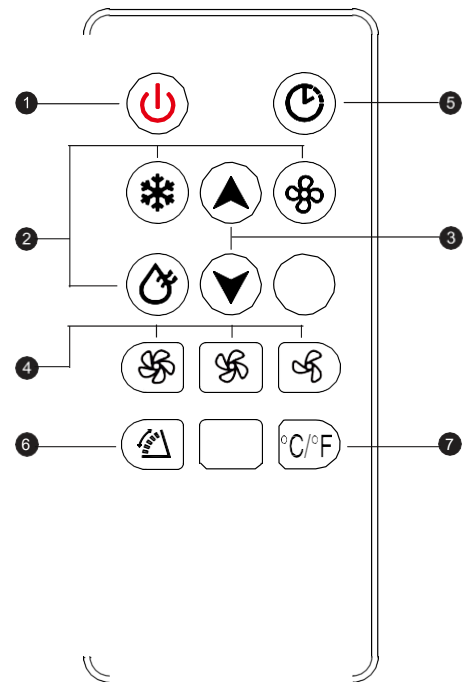

PRODUCT OPERATION

PLACEMENT AND INSTALLATION

Placement

- Place it at even and dry place, and keep it at least 50cm away from its surrounding object.

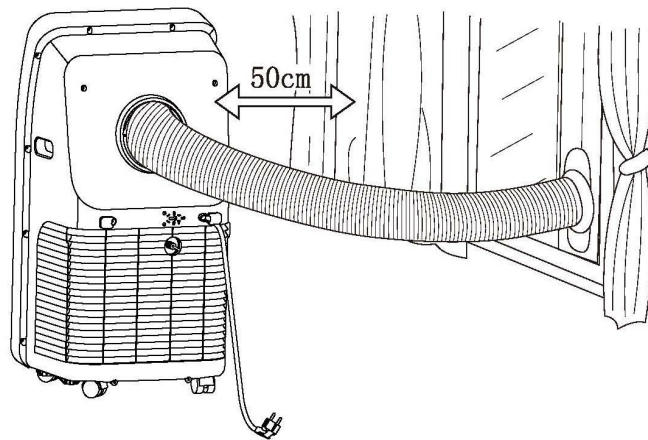

Installation

- Screw the exhaust duct assembly in the air outlet behind the panel (anticlockwise).

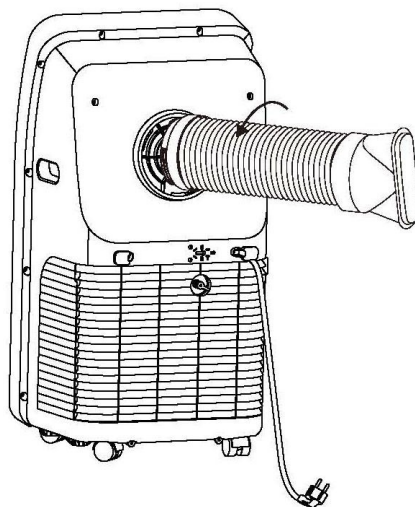

- Insert the air exhaust hose into the window sealing plate, adjust opening width of window so that the window can match with the sealing plate properly; length of the sealing plate is adjustable.

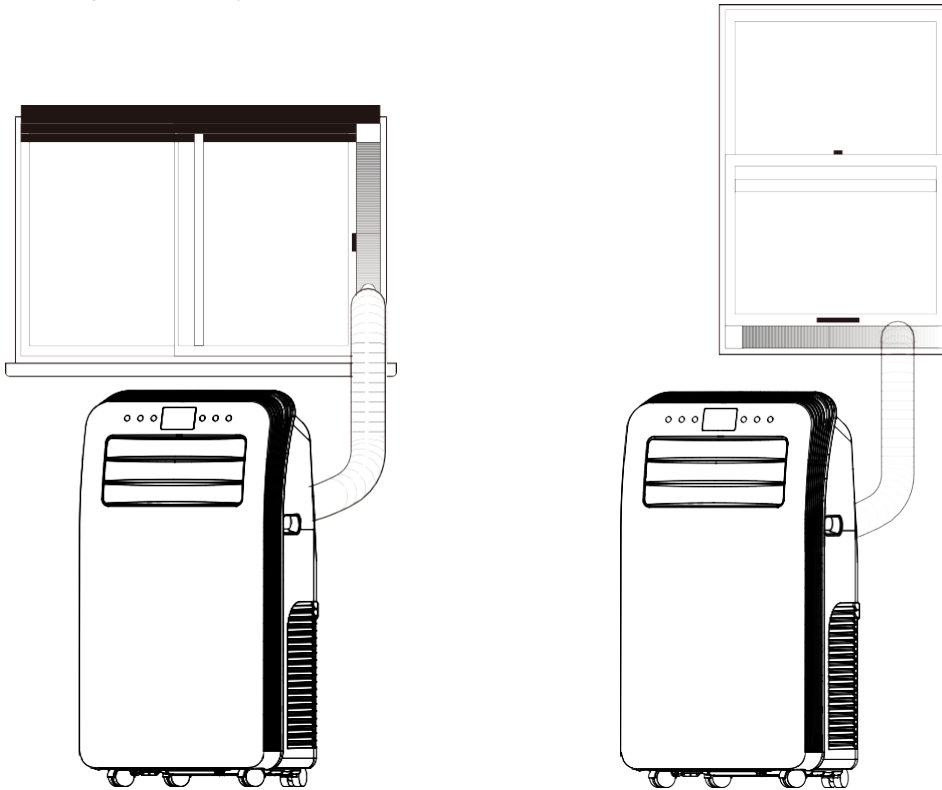

Incorrect installation

- It's important to keep the exhaust duct smooth. Incorrect installation will affect work of the A/C.
- Prevent the exhaust duct from seriously bending.
- Ensure air can flow smoothly in the duct.

Warning:

The exhaust duct is designed especially for this model. Don't replace or lengthen it; otherwise, it will result in failure.

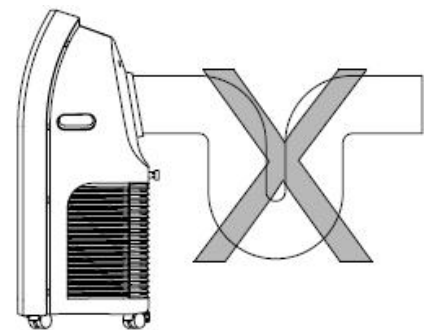

Notice:

Max. developed length of the exhaust duct is 1,500mm. It's better to shorten it while use and keep it horizontal while installation.

OPERATION METHOD

Cooling mode

- When the A/C enters cooling mode automatically or cooling mode is selected after power ON, the cooling indicator lamp lights up.
- Press Up/Down key to adjust setting temperature (16°C~30°C).
- Press Speed key to choose High/Mid/Low speed.

Fan mode

- When pressing mode key or choosing Fan mode by pressing the remote controller, the wind indicator lamp lights up.
- Press Speed key to choose High/Mid/Low speed.
- Temperature can't be set.

Dehumidification mode

- When pressing mode key or choosing dehumidification mode by pressing the remote controller, the dehumidification indicator lamp lights up.
- Remove the dehumidification water wedge, insert water manifold, place the other end of the water manifold into the water vessel or drainage passage, as shown in the right figure.
- After entering the dehumidification mode, if room temperature $\geq 17^{\circ}\text{C}$ (62°F), the compressor is ON. Then control as follows: when room temperature $\leq 15^{\circ}\text{C}$ (59°F) the compressor is OFF; when temperature increases to room temperature $\geq 17^{\circ}\text{C}$, the compressor is started again (in order to protect the compressor, it will be restarted 3min. later).
- In dehumidification mode, the fan is defaulted to run at low speed, and wind speed can't be adjusted.
- Temperature can't be set. (**Note : when use dehumidify function, should remove exit pipe components, otherwise, it will cause worse dehumidify performance, and appear "FL" water full alarm**)

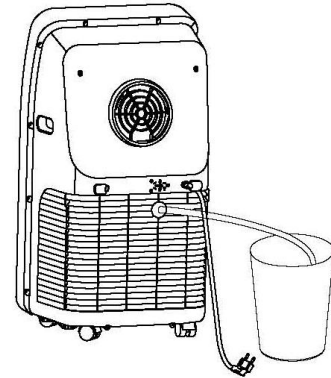

Timer mode

- In standby state, press the Timer key to set ON time. Press Up and Down keys to set ON time (1~24H), and the timer indicator lamp lights up.
- In ON state, press the timer key to set OFF time. Press Up and Down keys to set OFF time (1~24H), and the timer indicator lamp lights up.

CLEAN AND MAINTENANCE

DRAINAGE METHOD

This product is equipped with automatic water vaporization system. The condenser is cooled with the circulating of condensing water, so as to improve cooling efficiency and save energy.

- If the internal vessel is full of water, the display screen will display "FL", and the compressor stops working automatically. After power off, unscrew the water cover, pull out the water wedge to drain off water, and it will become normal after being restarted.

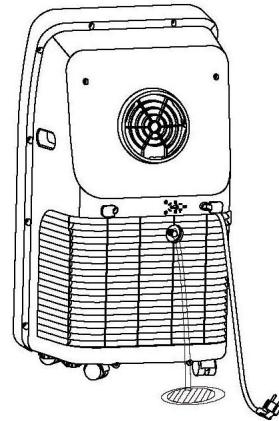

MAINTENANCE

Notice: in order to avoid electric shock, please turn off the A/C and unplug before maintenance or repair.

CLEANING

- Unplug before cleaning.
- Wipe with soft semi-dry cloth. Don't use chemical reagent, such as benzene, alcohol and gasoline etc.; otherwise surface of the A/C and even the whole A/C will be damaged.
- Prevent water from spattering in the A/C.

FILTER SCREEN

- Wash the filter screen once every two weeks. If it is blocked by dust, efficiency of the A/C will be reduced.

- Take out the air inlet grille and pull out the filter screen at both sides according to the direction shown in the following figures.
- Put the filter screen into the warm water (about 40°C) added with neutral detergent, dry it at a shady place after cleaning.

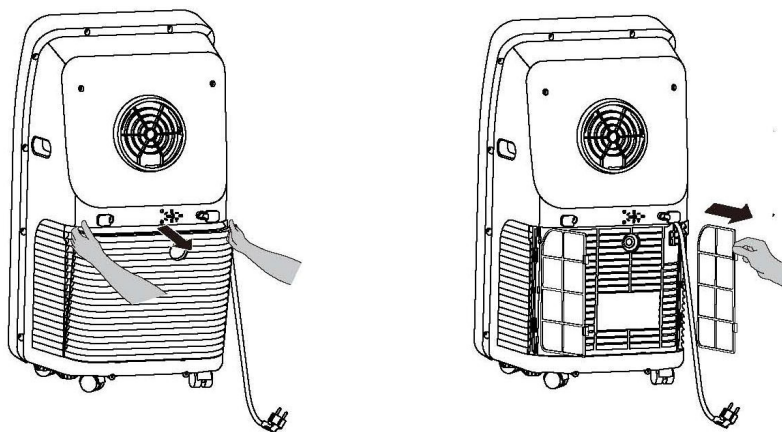

SEASONAL CLEANING

If the A/C will not be used for a long time:

- Pull out the water wedge to drain.
- Run the A/C in fan mode for 2H till its inside is dry.
- Turn off the A/C and unplug.
- Wash the filter screen and reassemble it.
- Dismantle the exhaust duct and keep it properly.
- Cover the A/C with a plastic bag and place it at a dry place.

COMMON FAILURES AND DIAGNOSIS

INTELLIGENT ERROR DETECTION

Error-detecting code	Multi-functional defection
E1	Error of the coil's temperature sensor
E2	Error of indoor temperature sensor
E4	Anti-freezing protection: temperature of the coil is too low and the whole A/C is off. When temperature exceeds 8°C, the protection is released and previous working state is recovered.

FUSE PARAMETERS

Specification: $\Phi 5 \times 20$ mm

Voltage: 250VAC

Current: 3.15A

TROUBLE-SHOOTING

In case of any of the following trouble, please contact professional maintenance personnel in time.

TROUBLE	CAUSE	SOLUTION
The A/C doesn't work	Not plug in	Plug in
	The display panel displays "FL"	Restart the A/C after power off and draining, then it will become normal
	Time OFF function is started	The A/C can be restarted 3 minutes after being turning off.
The A/C starts frequently	Direct sunlight	Draw the curtain
	Doors and windows keep open; there are lots of people or heat source in room	Close doors and windows, remove heat source
	Filter screen is very dirty	Clean or replace it
	Air inlet or air outlet is blocked	Remove the stem
Big noise of the A/C	The A/C is placed unevenly	Place it at even and firm ground, avoid shaking
The compressor doesn't work	Its delay protection is started	Wait for 3min., turn on it after temperature decreases

Notice: When there is any abnormal to the A/C, turn it off and unplug, and then contact professional maintenance personnel.

The above technical parameters are subject to change without notice.



■ Meaning of crossed –out wheeled dustbin:

Do not dispose of electrical appliances as unsorted municipal waste, use separate collection facilities.

Contact your local government for information regarding the collection systems available. If electrical appliances are disposed of in landfills or dumps, hazardous substances can leak into the groundwater and get into the food chain, damaging your health and well-being.

Here For You

After-sales assistance

If you continue to experience problems with your appliance, please call the Montpellier customer service helpline on: **01527 888133**

Please have all your product details available, including the model number, serial number, original sales invoice (clearly showing model number, date of purchase and your retailer's details) before registering a fault.

The service call cannot progress without this information.

Your 2 year Manufacturer's guarantee

THIS DOES NOT AFFECT YOUR STATUTORY RIGHTS.

Your new Montpellier appliance carries a free guarantee which protects you against the cost of repairs during the first 24 months from date of purchase provided that:

Any claim is accompanied by evidence of the model reference, model serial number and proof of purchase, such as a Sales Receipt, showing that the appliance was purchased within the 24 months prior to the date of claim.

What is not covered under the Guarantee

- Any appliance not correctly installed and operated in accordance with the manufacturer's instructions
- Any appliance that is used for anything other than domestic purposes.
Any defect caused by accident, misuse, unauthorised modification or inexpert repair.
- Cost of Call-out where a fault cannot be found with the appliance.
Cost of Call-out for work covering routine maintenance, such as, but not exclusively, cleaning of filters or defrosting.
- Cost of Call-out for work required to correct the alignment of doors following door reversal procedures carried out by you.
Use of the appliance by anyone other than the Householder.
Use in any commercial environment.
- Consumable items, such as, but not exclusively, fuses in plugs, bulbs and breakable items which require routine replacement.
Repair costs incurred that have not been authorised by Montpellier service and/or carried out by a non-approved Montpellier engineer.
- Montpellier Appliances do not accept claims for consequential loss, rusting, corroding, delivery damage or scratches.

YOUR GUARANTEE IS VALID ONLY IN THE UK & REPUBLIC OF IRELAND

To register your appliance simply complete the card in your appliance pack and return it with a stamp affixed or alternatively you can register online at www.montpellier-appliances.com/support

SERVICE HELP-LINE

Should your appliance develop a fault, please call the Montpellier customer service helpline on:

01527 888133

Please remember to have all your product details available, including the model number, serial number, date of purchase and your retailer's details before registering a fault.

Montpellier Domestic Appliances Ltd.

Unit 1, Tewkesbury Retail Park, Northway Lane,
Tewkesbury, Gloucestershire GL20 8JU

www.montpellier-appliances.com



The symbol on the product or on its packaging indicates that this product may not be treated as household waste. Instead it shall be handed over to the applicable collection point for the recycling of electrical and electronic equipment. By ensuring this product is disposed of correctly, you will help prevent potential negative consequences for the environment and human health, which could otherwise be caused by inappropriate waste handling of this product. For more detailed information about recycling of this product, please contact your local city office, your household waste disposal service or the shop where you purchased the product.